



BLR2 LITE MKII

User Manual
Version 1.1



SAFETY INSTRUCTIONS

1. Read this manual carefully.
2. Follow all instructions and warnings.
3. Only use accessories specified by WORK PRO.
4. Follow the safety instructions of your country.
5. Be careful with sound levels.

SYMBOLS

The following symbols are used in this document:



This symbol indicates a potential risk of harm to a person or damage to the product. You can also notify the user of the instructions that must be followed strictly to ensure the installation or safe operation of the product.



This symbol notifies the user about the instructions that must be followed strictly to ensure the correct installation or operation of the product.



This symbol notifies the user about additional information or optional instructions.

WELCOME TO WORK PRO

Thank you for choosing the WORK PRO BLR2 LITE MKII system.

This document contains essential information on the use of the system. Read this document carefully to become familiar with the system.

Please check the WORK PRO website regularly to download the latest version of the document and software updates: <https://www.workpro.es/>

CONTENT

1. INTRODUCTION.....	3
2. Components of the BlueLine Digital MKII System	4
3. RECEIVERS.....	4
3.1. Audio extracting methods.....	5
3.1.1. DUAL.....	5
3.1.2. SINGLE	5
3.1.3. MONO.....	6
3.1.4. INVERT OUT.....	6
4. BLR2 LITE MKII.....	7
4.1. Features	8
4.2. Device description.....	9
4.2.1. Display	9
4.2.2. Analog audio output.....	11
4.2.3. LAN port	12
4.2.4. Control.....	12
4.2.5. Main supply input.....	12
4.3. Device setup.....	12
4.3.1. Setup through WorkCAD3 Configurator	12
4.4. Accessories.....	14

1. INTRODUCTION

The devices of the BlueLine Digital MKII series allow the streaming of audio over IP through Ethernet, complying with the TCP / IP protocol stack. Using the BlueLine Digital MKII system it is possible to perform from a simple point-to-point audio transmission to a complex multi-channel system with alarm control and management.

BlueLine Digital MKII can make use of the existing physical network infrastructure in the installation, due to its low bandwidth consumption. On the other hand, it is compatible with commonly used low or high impedance amplification systems.

Thanks to the modular design of the system, BlueLine Digital MKII adapts perfectly to the features of each installation, being able to expand the system in the future if the characteristics of the installation require it.

Features:

- Management of audio streamers and receivers.
- Different types of coding (PCM, MP3).
- Different audio extraction modes (Dual, Single, Mono).
- Control by OSC commands.
- Control by GPIO.
- Complement with the family of Light Mouse devices.
- Real-time system monitoring.
- Configuration by software.
- External power supply or PoE.

2. Components of the BlueLine Digital MKII System

In this chapter you will find information about the different devices that make up the BlueLine Digital MKII system.

The BlueLine Digital MKII system has four kinds of devices:

STREAMERS	BLS2 LITE MKII	One stereo channel sender
	BLS2 SD MKII	One stereo channel sender with SD player
RECEIVERS	BLR2 LITE MKII	One stereo channel receiver
	BLR2 MKII	One stereo channel receiver with 2xGPIs/2xGPOs
	BLR2 A plus MKII	One stereo channel receiver with 2xGPIs/2xGPOs and low impedance amplifier
PAGING	SPS 8	Paging station
WALLMOUNT CONTROLLERS	BLC 1	Wallmount controller for local receiver
	WNC 1	Wallmount controller through the network
	WAC 7	Customizable wallmount controller

Note: The BlueLine Digital MKII series is compatible with the previous series of devices, so you can include devices of both series in your installation.

3. RECEIVERS

The BlueLine MKII receivers are devices that are responsible for extracting one stereo audio channel from the network. There are three types of receivers:

BLR2 LITE MKII: Receiver of one stereo channel.

BLR2 MKII: Receiver of one stereo channel with 2GPIs / 2GPOs.

BLR2 A PLUS MKII: Receiver of one stereo channel with amplification module and 2xGPIs / 2xGPOs.

BlueLine receivers do not consume bandwidth by audio transmission. Its consumption is associated with UDP / OSC state packets and OSC control packets. This consumption will be disregarded, since it is minimal and it will depend on each specific use.

3.1. Audio extracting methods

It is important to emphasize that each audio receiver is only capable of extracting one stereo audio channel from the network. The extraction of this channel can be done in different ways, that can be select in the configuration interface of WorkCAD3 Configurator.

3.1.1. DUAL

Stereo extraction mode. Each input is assigned to its output.

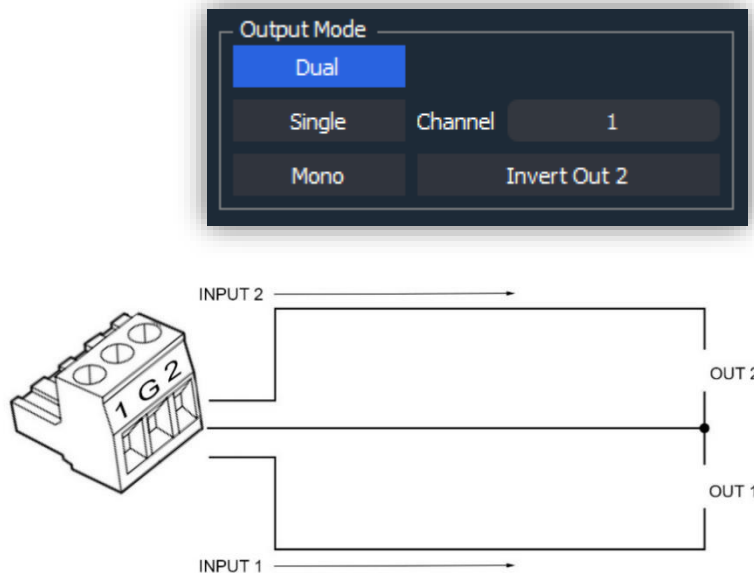

3.1.2. SINGLE

Individual extraction mode. Of the two parts that one stereo channel is conformed (1-L or 2-R), we choose one of them, to extract it by both outputs of the receiver. In this example we select 1-L

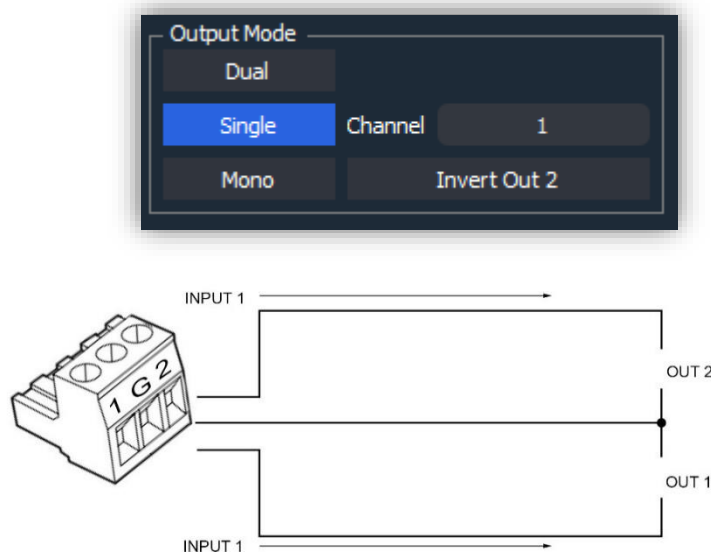

3.1.3. MONO

Mono extraction mode. The two input channels (1-L and 2-R), are summed to extract them by both outputs of the receiver.

6 dB are subtracted from each output to compensate for the electrical sum of two input channels.

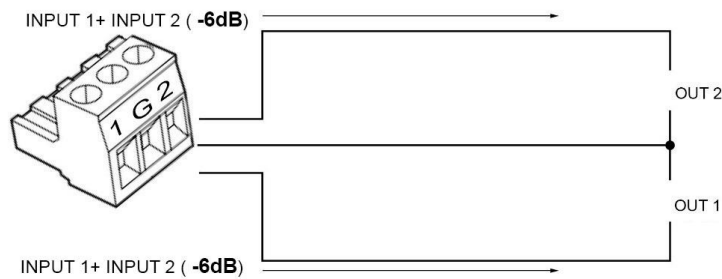
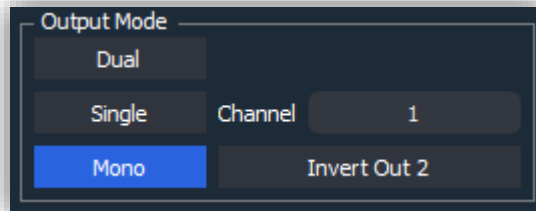

3.1.4. INVERT OUT

Inversion of the polarity for output 2, in order to create a balanced output. This option is only available for SINGLE and MONO modes. In this case, we select MONO mode.

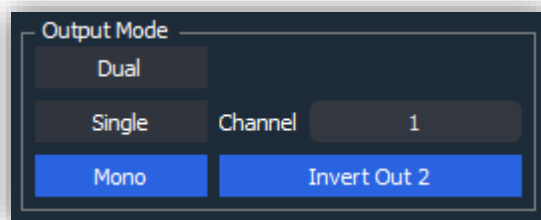

4. BLR2 LITE MKII



The BLR2 Lite MKII is an audio over IP receiver, that can extract one of the channels transmitted by the BlueLine MKII senders.

The device can be powered by either PoE or an external power supply.



It is important to stress that one receiver cannot mix channels from different senders.

4.1. Features

Analog audio output	
Number of channels	1 stereo channel (unbalanced) or 1 single/mono channel (balanced)
Audio connector	Euroblock, 3 pin 5.08mm
Output sensitivity	-1.15 dBu (640mV _{rms})

Network	
Connector	RJ-45
Audio over IP	BlueLine UDP datagram
Ethernet	100 base TX

Main supply	
External power supply	12/24 Vdc (Not included)
PoE Class	Class 0 802.3af
Consumption	1.5 W

General	
Control protocol	OSC
Audio extraction modes	Stereo/Single/Mono
Dimensions	109mm×133.75mm×40.45 mm
Weight	360 g

4.2. Device description

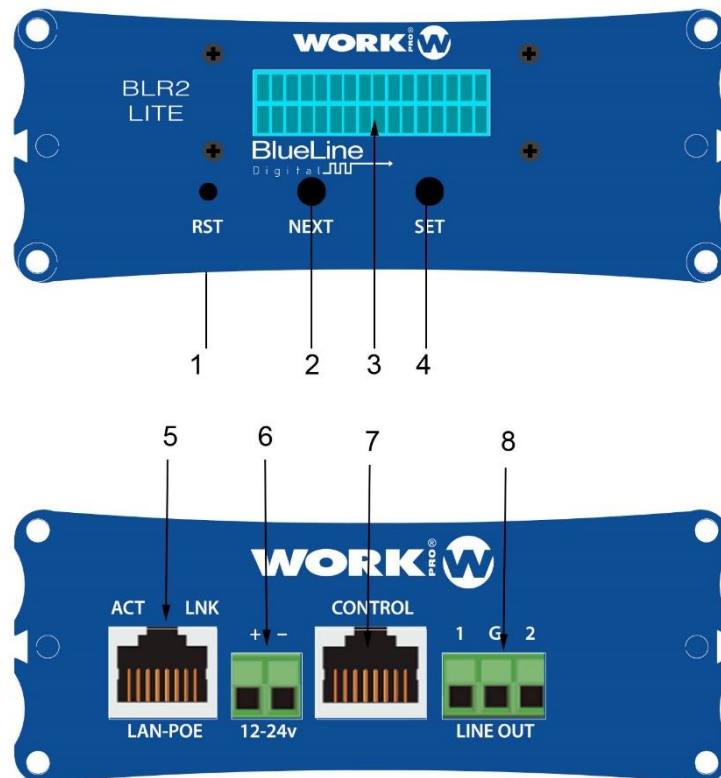

1. **Reset button.** Take the device to its factory configuration
2. **Next button.** It allows to advance between and through the different screens of the display.
3. **Display.** It shows different features of the device.
4. **Set button.** It allows access to a certain display screen and set the digits of the different screens.
5. **LAN port.** Connection port to the local network, RJ45.
6. **Main supply input.** 12/24 Vdc
7. **Control.** Connection port for the BLC 1 wallmount controller (RJ 45)
8. **Analog audio output.** Unbalanced or balanced audio output, (depending on the extraction method), 3-pin Euroblock of 5.08 mm.

4.2.1. Display

On the front of the device you will find a display through which you can view or modify different parameters of the unit.

To navigate between the different parameters press the NEXT button if you want to edit any of these parameters, press the SET button to access it. Next, specify which parameters are editable and which are not:

- STATIC IP, editable.
- DYNAMIC IP, not editable.
- MAC, not editable
- SRC, editable.
- VOL, editable



STATIC IP: 18
010.001.027.234

STATIC IP, this is the static IP address. The device has a static IP address by default in the subnet 10.0.0.0/8. For editing, use the SET (to select and set the digit) and NEXT (for editing upwards) buttons.

NOTE: After a change, the device restarts to confirm the value.



DYNAMIC IP:
192.168.001.100

DYNAMIC IP, this is the dynamic IP address of the device, which is assigned by a DHCP server.



MAC: 00-25-80
00-18-EA

MAC, this is the physical address of the device.



SRC: 1
VOL: -2 DB

SRC, it refers to the channel (Source) in which the device transmits. For editing, use SET (to select and set the digit) and NEXT (for editing upwards) buttons.

VOL, It refers to the master volume of the device, and can be modified between the values [-40dB, 3dB]. For editing, use SET (to access and set the volume) and NEXT (for editing upwards) buttons.

4.2.2. Analog audio output

The analog audio output of the device can be balanced or unbalanced according to the selected extraction mode. keep in mind the following types of connection:

STEREO UNBALANCED

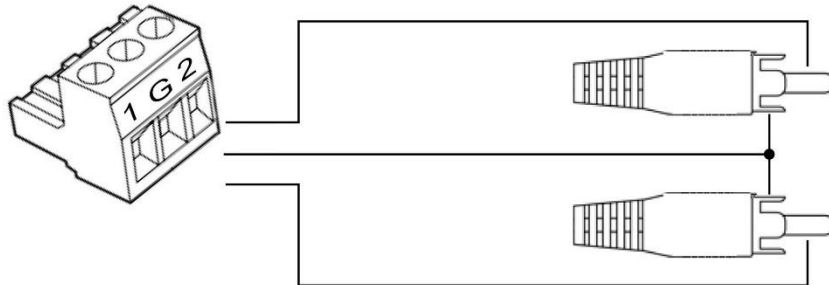

MONO UNBALANCED



MONO BALANCED

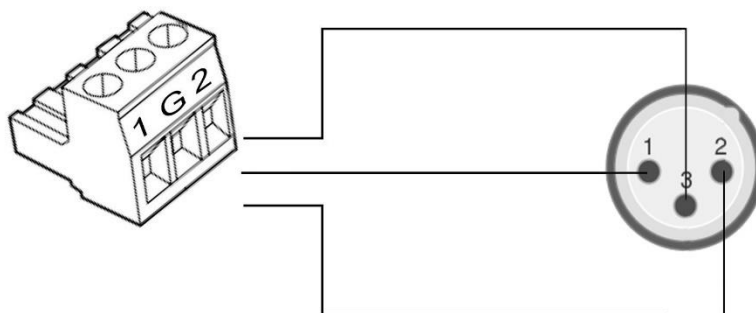

4.2.3. LAN port

RJ45 port for LAN connection. Allows PoE power (Class 0 802.3af)

Next to the RJ45 connector you will find two LEDs indicating the status of the device:

LINK (green)	Indicates that the BLS2 LITE MKII is connected to the LAN
ACT (orange)	Indicates that packets are being sent or received

4.2.4. Control

This port allows the connection of a BLC 1 wall controller acting as a local controller. In this way, it is possible to select the audio source to be extracted and its volume.

4.2.5. Main supply input

Power input for external source. The admitted voltage can be between 12/24 Vdc, with a minimum current of 500 mA.



Check the current polarity before connecting the main supply



The external power supply is not provided with the device.

4.3. Device setup

The configuration of the device can be done by software (WorkCAD3 configurator) or through display. The most comfortable way for the user is through WorkCAD3 configurator, since he will have access to all the functionalities of the device and he can also see the interaction of the device with the rest of the BlueLine Digital MKII network elements.

4.3.1. Setup through WorkCAD3 Configurator

After making the IP level configuration of the device and updating it if would be necessary (see **WorkCAD3 Configurator manual**), proceed with its setup.

If you click on the device with the left mouse button, the configuration interface will be opened and the following parameters will appear:

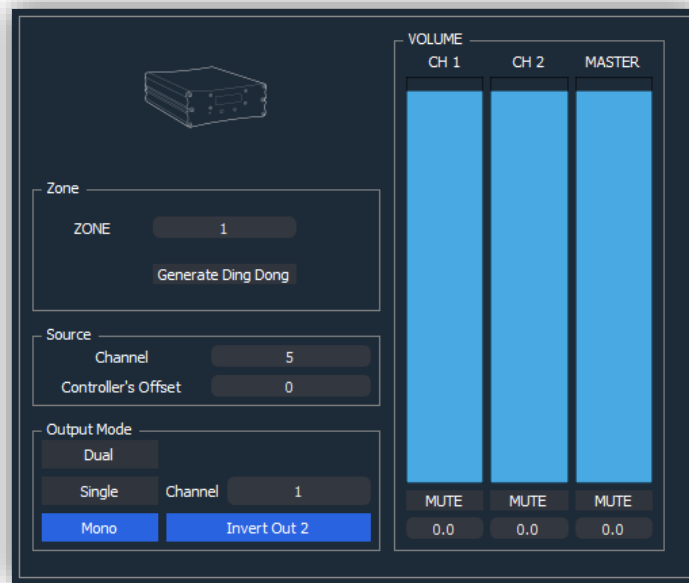

- **Zone:** This field refers to the zone to which the device belongs, in order to receive OSC control commands. By default, all BlueLine receivers are in zone 1.
- **Generate Ding Dong:** Button to execute a Ding Dong signal in the receiver. It is useful to recognize/check the speakers connected to this receiver.
- **Channel:** Number of the stereo audio channel that we want to extract.
- **Controller's offset:** Field to enter an offset in the wallmount controller (BLC 1 or WNC 1) that manage the device. For example, if we enter "1" in this field, the minimum channel that can be chosen in the wall-control will be "1", so if we have a reserved source in channel "0", the user will not be able to access it.
- **Output mode:**
 - **Dual:** Stereo audio extraction.
 - **Single:** Audio extraction in individual mode.
 - **Mono:** Extraction of audio in mono mode, adding the two channels and extracting it for both outputs with an attenuation of -6 dB.
 - **Channel:** Selection of the channel to be extracted in individual mode. 1 (L) or 2 (R).
 - **Invert Out 2:** Polarity inversion of output 2 to obtain a balanced output. Only available in Single and Mono modes.



See section 3.1 (Audio extraction methods), for more details.

- **Volume:** Field dedicated to control the volume and mute of channels 1, 2 and Master.

4.4. Accessories

The BLR 2 Lite MKII includes a series of accessories for mounting on a wall or with the rack accessory BL AR 19 (not included):

- 2x Wings for mounting in a wall.
- 4 screws.
- 1x Bar to joint two devices.

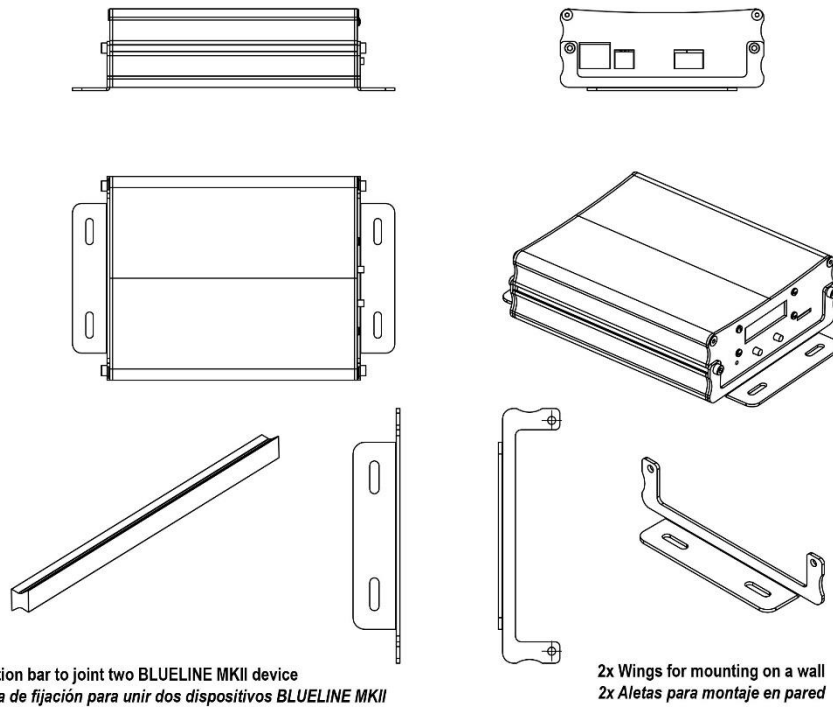

- Optional -

BL AR 19

Fixing accessory for standard rack 19" 1 HU to house up to 4 devices of the BlueLine MKII series.

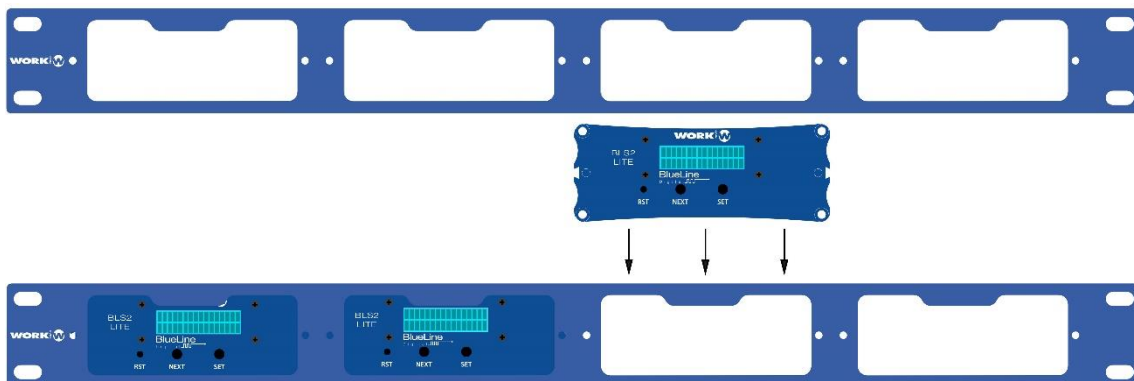



Av. Saler nº 14 Polígono. Ind. L`Alteró. Silla 46460 VALENCIA-SPAIN
Tel: +34 96 121 63 01
www.workpro.es